

A GUIDE FOR PARISHES AND ORGANIZATIONS

Exhibit Designed by Blessed Carlo Acutis

Eucharistic Miracles OF THE WORLD



Encounter Jesus!

spiritcatholicradio.com/miracles
855-571-0200 | kvss@kvss.com



Vatican International Exhibition

EUCCHARISTIC MIRACLES OF THE WORLD

TABLE OF CONTENTS

What is a Eucharistic Miracle?	4
Eucharistic Miracles Included in the 41 Panel Exhibit	6
Eucharistic Miracles Included in the 157 Panel Exhibit.....	7-11
Exhibit is Free to View.....	12
Invite the Knights of the Holy Eucharist to Speak at Your Exhibition Event.....	12
Promote Your Exhibition.....	13-14
Additional Marketing Suggestions.....	14-15
Manage the Exhibition/Table Materials.....	15-16
Pick-Up, Transport and Return of the Exhibit.....	17
Set-Up and Take Down of the Exhibit.....	18-22
Additional Information About the Eucharistic Miracles.....	23
Best Practices: Get Youth Engaged in Your Exhibition Event.....	24
Frequently Asked Questions.....	25
Attachments.....	26-28

Eucharistic Miracles of the World

Guide for Parishes and Organizations

WHAT IS A EUCHARISTIC MIRACLE?

Eucharistic miracles consist of unexplainable phenomena occurring after transubstantiation, such as a host visibly transforming into human tissue, a host surviving fire, a host bleeding or the Eucharist alone providing sustenance to a human being for a prolonged period of time. In order to be considered a Eucharistic miracle, the event is investigated by a special task force before deciding it is worthy of belief. Secular sources are often used to investigate and confirm the miracle. Belief in approved miracles is not mandated by the Catholic Church, but can reassure believers of God's presence in our world.

"Now as they were eating, Jesus took bread, and blessed, and broke it, and gave it to the disciples and said, 'Take, eat; this is my body.' And he took a cup, and when he had given thanks he gave it to them, saying, 'Drink of it, all of you; for this is my blood of the covenant, which is poured out for many for the forgiveness of sins.'"



ABOUT THE EXHIBIT

Spirit Catholic Radio is proud to be the home of three sets of the powerful *Eucharistic Miracles of the World* exhibit. We've made the exhibit available to the public by loaning it to parishes and organizations at no cost.

This Vatican-approved international exhibit was designed and created by Blessed Carlo Acutis. Carlo, an artist, cartoonist and avid computer enthusiast, created the art for the panels before his death from leukemia at age 15. His goal during his short life was to help bring others closer to Jesus through awareness of the mystery of the Eucharist. Carlo received the sacrament of the Eucharist daily and desired to share the joy of Christ's presence with the world through his God-given talents. This exhibit is presented in the United States by the Carlo Acutis Association.

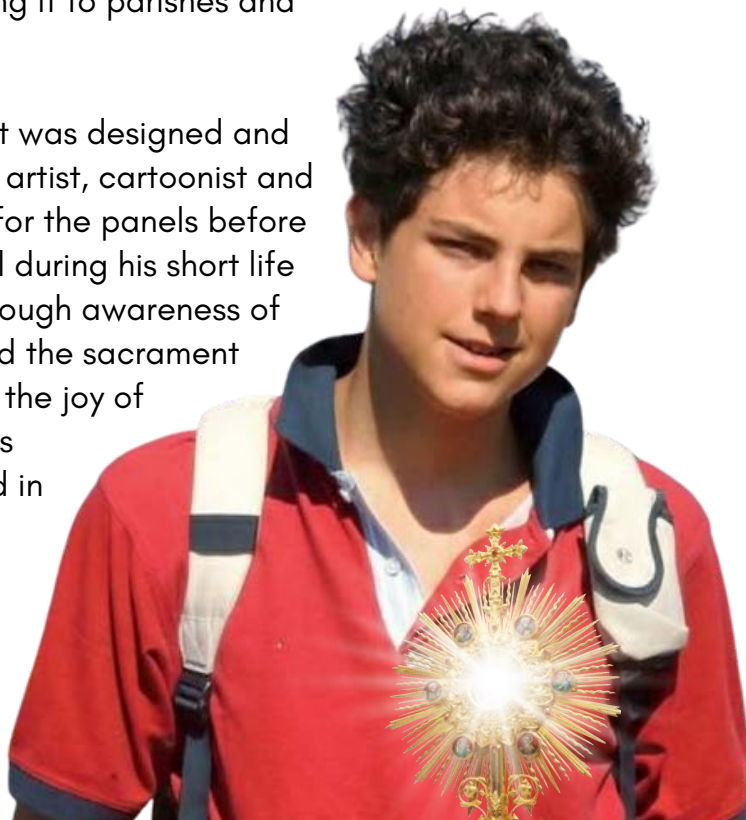

ABOUT THE EXHIBIT CONTINUED...

Two of our Eucharistic Miracle exhibits feature 41, 2'x5' detailed vinyl panels highlighting some of the most powerful Eucharistic Miracles of the World. The panels were selected from 126 recognized accounts that date from as early as the third century. Our third exhibit features 157 corrugated board panels that highlight all 126 Eucharistic Miracles. Each panel tells the story of a Eucharistic miracle and is accompanied by photos and artwork. All of the miracles displayed in this exhibition have been recognized by their local bishops. The exhibit's purpose is to increase awareness of the Real Presence of our Lord in the Eucharist and promote Eucharistic adoration.



41 Panel Display



157 Panel Display

EUCCHARISTIC MIRACLES INCLUDED IN THE 41 PANEL EXHIBIT

The following is a list of the Eucharistic Miracles of the World panels that are part of the Spirit Catholic Radio traveling exhibit.



Eucharistic Miracles of the World Exhibit Panels

1. Vatican International – Intro Panel
2. Miraculous Communion I (6 Miracles)
3. Miraculous Communion II (12 Miracles)
4. Lanciano, Italy I – 750
5. Lanciano, Italy II – 750
6. Santarem, Portugal I – 1247
7. Santarem, Portugal II – 1247
8. Bolsena, Italy I – 1264
9. Bolsena, Italy II – 1264
10. Paris, France I – 1290
11. Paris, France II – 1290
12. O’Cebreiro, Spain – 1300
13. Erding, Germany – 1417
14. Avignon, France I – 1433
15. Avignon, France II – 1433
16. Turin, Italy I – 1453
17. Turin, Italy II – 1453
18. Salzano, Italy – 1517
19. Faverney, France – 1608
20. Turin, Italy – 1640
21. Montserrat, Spain – 1657
22. Siena, Italy – 1730
23. Onil, Spain I – 1824
24. Onil, Spain II – 1824
25. Tumaco, Columbia – 1906
26. Fatima, Portugal – Angel of Peace I – 1916
27. Fatima, Portugal – Angel of Peace II – 1916
28. Fatima, Portugal – Angel of Peace III – 1916
29. Andre Frossard, Atheist Writer – 20th Century
30. Buenos Aires, Argentina I – 1992-1994-1996
31. Buenos Aires, Argentina II – 1992-1994-1996
32. Buenos Aires, Argentina III – 1993-1994-1996
33. Chirattkonam, India – 2001
34. Tixtla, Mexico I – 2006
35. Tixtla, Mexico II – 2006
36. Sokolka, Poland I – 2008
37. Sokolka, Poland II – 2008
38. Sokolka, Poland III – 2008
39. Spirit Catholic Radio Thank You – Outro Panel
40. Additional panel about Bl. Carlo Acutis
41. Additional panel about Bl. Carlo Acutis

Of the 41 panels, you will notice that the first panel is an intro panel and the last panel is an outro panel. Some panels in the exhibit have several miracles contained in one panel. Likewise, there are several miracles that have more than one panel illustrating the miracle. Therefore, when you receive the exhibit from Spirit Catholic Radio, be aware that the back of each panel is sequentially numbered (see the top number in the upper left-hand corner of the back of the panel) to match the list above. The set-up of the panels should be placed in numerical and date order to ensure that the grouping of the panels for the miracles are in proper sequence. Panels 40/41 can be placed near materials table. Each panel has its own easy-to-assemble, x-frame stand. The panels illustrate both graphic and written depictions of the miracles.

EUCCHARISTIC MIRACLES INCLUDED IN THE 157 PANEL EXHIBIT

The following is a list of the Eucharistic Miracles of the World panels that are part of the Spirit Catholic Radio traveling exhibit.



Posters arranged alphabetically by country and then chronologically within each county.

*(String 1 for **Row 1** in Box 1 - 10 panels, 20 posters)*

FRONT

Miraculous Communion Part 1
Miraculous Communion Part 2
IV Century St Satyrus
1224 - 1274 St Thomas Aquinas
1550 - 1568 St Stanislaus Kostka
1638 - 1686 Bl. Nicholas Steno (Steensen)
XX Century Andre Frossard
Argentina 1992 Buenos Aires #1
Argentina 1994 Buenos Aires #2
Argentina 1996 Buenos Aires #3

BACK

Germany 1330 Walldurn
Germany 1280 Kranenburg
Germany 1255 Regensburg
Germany 1216 Benningen
Germany 1194 Augsburg
Germany 1125 Bettbrunn
Germany 1898-1962 Theresa Neumann
Germany 1774-1824 Blessed Ann Emmerich
Germany Weingarten #2
Germany Weingarten #1

(String 2 for **Row 1** in Box 1 - 12 panels, 24 posters)

FRONT

BACK

Austria	1310	Fiecht
Austria	1384	Seefeld
Austria	1411	Weiten-Raxendorf
Belgium	1203	Bruges
Belgium	1317	Herkenrode-Hasselt
Belgium	1370	Brussels
Belgium	1374	Middleburg-Lovanio
Belgium	1374	Liege (Corpus Christi)
Belgium	1405	Bois-Seigneur-Isaac
Belgium	1412	Herentals
Caribbean	1902	Morne-Rouge
Columbia	1906	Tumaco

France	1888	Lourdes
France	1822	Bordeaux
France	1668	Les Ulmes
France	1643	Pressac
France	1608	Faverney
France	1589	Pibrac - St Germaine Cousin
France	1533	Marseille-En-Beauvais
France	1461	La Rochelle & Neuvy Saint Sepulcre
France	1433	Avignon #2
France	1433	Avignon #1
France	1430	Dijon
France	1331	Blanot

(String 3 for **Row 1** in Box 1 - 6 panels, 12 posters)

FRONT

BACK

Croatia	1411	Ludbreg #1
Croatia	1411	Ludbreg #2
Egypt	IV-V cent	St. Mary of Egypt
Egypt	III-IV cent	Scete
France	XVII cent	St Margaret Mary
France	1902-1981	Alacoque-Sacred Ht Servant Marthe Robin

France	1290	Paris #2
France	1290	Paris #1
France	1254	Douai
France		St Egidio (St Gilles)
France	1830	St Catherine Laboure
France	XII cent	St Bernard & St John Bosco Chiar. Italy 1848



*This is an artistic representation of a Eucharistic Miracle. This is not a real Eucharistic Miracle

(String 4 for **Row 2** in Box 2 - 10 panels, 20 posters)

FRONT

Germany	1383	Wilsnack
Germany	1417	Erding
India	2001	Chirattakoman
La Reunion	1902	St Andre de la Reunion
Italy	1347-1380	St Catherine of Siena
Italy	1240	St Clare
Italy	XIII cent	St Francis of Assisi
Italy	XI cent	St Peter Damian & Scala (1732)
Italy	1230-1595	Florence
Italy	VI-VII cent	Rome VI-VII Century #1

BACK

Peru	1649	Eten
Netherlands	1572	Gorkum-El-Escorial
Holland	1429	Alkmaar
Holland	1421	Bergen
Holland	1400	Boxmeer
Holland	1380	Boxtel-Hoogstraten
Holland	1345	Amsterdam #2
Holland	1345	Amsterdam #1
Holland	1342	Stiphout
Holland	1300	Breda-Niervaart

(String 5 for **Row 2** in Box 2 - 12 panels, 24 posters)

FRONT

Italy	VI-VII cent	Rome VI-VII Century #2
Italy	750	Lanciano #1
Italy	750	Lanciano #2
Italy	XI cent	Trani
Italy	1171	Ferrara
Italy	1227	Rimini
Italy	1228	Alatri
Italy	1264	Bolsena #1
Italy	1264	Bolsena #2
Italy	1273-1280	Offida
Italy	1294	Gruaro (Valvasone)
Italy	1330	Cascia

BACK

Holland	1222-1465	Meerssen
Mexico	2006	Tixtla #2
Mexico	2006	Tixtla #1
Mexico	1531	Guadalupe
Italy	1948	Rosano
Italy	1866-1912	Bl. Mary of Passion
Italy	1772	Patierno (Naples)
Italy	1730	Siena
Italy	1718	Asti #2
Italy	1656	Cava dei Tirreni
Italy	1640	Turin #3
Italy	1631	Dronero & St Mauro La Bruca

*(String 6 for **Row 2** in Box 2 - 6 panels, 12 posters)*

FRONT

Italy	1356	Macerata
Italy	1412	Bagno di Romagna
Italy	1453	Turin #1
Italy	1453	Turin #2
Italy	1472	Volterra
Italy	1517	Salzano

BACK

Italy	1630	Canosio
Italy	1610	Rome #3
Italy	1604	Mogoro
Italy	1570	Veroli
Italy	1560	Morrovalle
Italy	1535	Asti #1

*(String 7 for **Row 3** in Box 3 - 10 panels, 20 posters)*

FRONT

Poland	XX cent	St Faustina Kowalska
Poland	1290	Glotowo
Poland	1345	Krakow
Poland	1399	Poznan
Poland	2008	Sokolka #1
Poland	2008	Sokolka #2
Poland	2008	Sokolka #3
Poland	2013	Legnica #1
Poland	2013	Legnica #2
Portugal	1904-1955	Bl. Alexandrina Maria de Costa

BACK

Venezuela	1991	Betania
Switzerland	1447	Ettiswil #2
Switzerland	1447	Ettiswil #1
Spain	1907	Silla
Spain	1824	Onil #2
Spain	1824	Onil #1
Spain	1657	Montserrat
Spain	1640	Calanda
Spain	1597	Alcala
Spain	1568	Alcoy



*This is an artistic representation of a Eucharistic Miracle. This is not a real Eucharistic Miracle

*(String 8 for **Row 3** in Box 3 - 11 panels, 22 posters)*

FRONT

Portugal	1916	Angel of Peace #1
Portugal	1916	Angel of Peace #2
Portugal	1916	Angel of Peace #3
Portugal	1247	Santarem #1
Portugal	1247	Santarem #2
Spain	1251	St John of the Abbesses
Spain		Valencia #1
Spain		Valencia #2
Spain	1010	Ivorra #1
Spain	1010	Ivorra #2
Spain	1231	Caravaca de la Cruz

BACK

Spain	1533	Ponferrada
Spain	1427	Zaragoza
Spain	1420	Guadalupe Spain
Spain	1392	Moncada
Spain	1370	Cimballa
Spain	1348	Alboraya-Almacera #2
Spain	1348	Alboraya-Almacera #1
Spain	1300	O'Cebreiro
Spain	1297	Gerona
Spain	1239	Daroca #2
Spain	1239	Daroca #1

Three single posters in box 3: Monstrance, Carlo Acutis, Miracles
 (77) Double sided panels, (3) Single sided panels, (157) Posters



*This is an artistic representation of a Eucharistic Miracle. This is not a real Eucharistic Miracle

EXHIBIT IS FREE TO VIEW

Because Spirit Catholic Radio provides the Eucharistic Miracles of the World exhibit at no cost to parishes and organizations, there must never be an admission fee or tickets sold for people to see the exhibit. However, Spirit Catholic Radio provides a locked donation box to accept free-will offerings. We ask you to place this donation box on a small display table near the exhibit. Funds collected are used for the upkeep of the exhibit and for print materials.

INVITE THE KNIGHTS OF THE HOLY EUCHARIST TO SPEAK AT YOUR EXHIBITION EVENT

The Knights of the Holy Eucharist (KHE), founded in 1998 by Mother Angelica of EWTN, are a community of consecrated lay Franciscan brothers dedicated to adoration of and fostering reverent devotion to Our Lord in the Most Blessed Sacrament of the Eucharist. Parishes and organizations booking the Eucharistic Miracles exhibit for display are also encouraged to invite the KHE to be present at your location to provide a customized talk as part of your exhibition event and promotion of the Eucharistic Miracles of the World.

The KHE will tailor their talks for parishes and organizations based on the group being addressed (e.g., young children, teens or adults). The KHE will want to understand what you would like to emphasize most regarding the Eucharist, depending on the audience. For instance, you may wish to highlight not only the benefits of attending regular or daily Mass to receive the Eucharist, but perhaps your parish or organization also has a goal to increase Adoration of Our Lord in the Blessed Sacrament and to promote more intentional Perpetual Adoration.

You may contact Brother David Mary to schedule one or more sessions about the Eucharist at your event while the Eucharistic Miracles of the World exhibit is being displayed. To arrange a talk by the KHE, you must email Brother David Mary directly. When checking availability with the KHE, a minimum of two weeks' notice is required ahead of the desired date of the event, but we suggest contacting them as soon as possible. All requests must also include details of scheduled dates, times, and expectations.

Please contact Brother David Mary directly at:

Knights of the Holy Eucharist

7303 N 112th Street

Waverly, NE 68462

Email: knightsinfo@gmail.com

Web: <http://www.knightsoftheholyeucharist.com/>

The KHE is a lay apostolate of consecrated Franciscan Brothers under the direction and guidance of the Diocese of Lincoln. We suggest you take up a charitable collection during their talk to help support the KHE's time, travel and expenses. The KHE does not receive financial support from the Diocese of Lincoln.

PROMOTE YOUR EXHIBIT

Upon agreeing to host the Eucharistic Miracles of the World exhibit, you may consider promoting your exhibition event with the following suggestions.

Bulletin and/or Pulpit Announcements

Provided below are two different templates (to be customized with your specific exhibition event location, display dates and viewing times) for inclusion into your parish bulletin and/or for use as a pulpit or intercom announcement. Feel free to also share this bulletin announcement with your neighboring parishes and encourage them to come and see the Eucharistic Miracles as well.

(Without the KHE):

Eucharistic Miracles of the World Coming to Parish Name

Parish Name will be hosting the Vatican-approved international Eucharistic Miracles of the World exhibit from Insert Display To-From Dates in the Parish Hall at Street Address, City Name. It is free to view from Time a.m. to Time p.m. on Day(s) of Week. The Eucharistic Miracles of the World exhibit is a traveling display on loan from Spirit Catholic Radio. It features 41 (or 157 depending on exhibit) beautiful panels that highlight some of the most powerful Eucharistic miracles in the world. For more information, visit spiritcatholicradio.com/miracles.

OR

(With the KHE):

Eucharistic Miracles of the World & Knights of the Holy Eucharist Coming to Parish Name

Parish Name will be hosting the Vatican-approved international Eucharistic Miracles of the World exhibit on Insert Display To-From Dates in the Parish Hall at Street Address, City Name. It is free to view from Time a.m. to Time p.m. on Day(s) of Week. The Eucharistic Miracles of the World exhibit is a traveling display on loan from Spirit Catholic Radio. It features 41 (or 157 depending on exhibit) beautiful panels that highlight some of the most powerful Eucharistic miracles in the world. For more information, visit spiritcatholicradio.com/miracles. While the Eucharistic Miracles of the World are here, we are honored to have the Knights of the Holy Eucharist deliver compelling sessions about the Eucharist. The Four Dimensions of Eucharistic Adoration is Monday, Date from Time-Time p.m., and The Mysteries of the Rosary: Shining Mirrors of God's Marvelous Love in the Holy Eucharist is Tuesday, Date from Time-Time p.m. The Knights of the Holy Eucharist are consecrated lay Franciscan brothers dedicated to fostering reverent devotion to Our Lord in the Most Blessed Sacrament.

8 ½ x 11 Flyer

Once your event is booked and confirmed, Spirit Catholic Radio will provide you with an editable Word template of an 8 ½ x 11 flyer (to be customized with your specific exhibition event location, display dates and viewing times). This flyer may be used for handouts and/or posting on your bulletin boards, or for use to insert into the bulletin as a separate sheet, or to attach in an email to invite parishioners, organizational members, Catholic schools and parents, or others to your event (see **Attachment A** for a sample completed flyer).

Free Online Events Calendar

Spirit Catholic Radio has a free online events calendar that receives thousands of views on a regular basis. We encourage parishes and organizations to post their exhibition event of the Eucharistic Miracles at <https://spiritcatholicradio.com/resources/events/community-events/>. It may take up to five business days for an event to appear in the online events calendar at <https://spiritcatholicradio.com/resources/events/>. See **Attachment B** for a sample calendar entry.

Purchase On-Air Announcements

If your parish or organization would like to further promote your exhibition event of the Eucharistic Miracles of the World, you may wish to consider purchasing on-air announcements, designed for non-profit organizations, to be mentioned on Spirit Catholic Radio. To view the affordable non-profit packages offered by Spirit Catholic Radio, including an online request form, visit our web page at <https://spiritcatholicradio.com/contact/purchase/>.

Additional Marketing Suggestions

Online Calendar for your Diocese:

- Omaha Archdiocese Online Calendar of Events: <https://archomaha.org/submit-an-event/>
- Des Moines Diocese Online Calendar of Events: Please send requests directly to Anne Marie Cox (ACox@dmdiocese.org). They list events that are open to the public and in the Des Moines Diocese with a focus on events that involve multiple parishes rather than events that are limited in scope to a specific parish or school. If your exhibition event is open to the public and in the Des Moines Diocese, please send it to Anne Marie Cox for consideration.
- Lincoln Diocese Online Calendar of Events: <http://www.lincolndiocese.org/calendar>. Please use the Submit button located directly above the calendar at the top of the page
- Grand Island Diocese Online Calendar of Events: <http://www.gidiocese.org/about-us/contact-us>

Diocesan Newspaper:

- Omaha Archdiocese Newspaper - The Catholic Voice:
 - <http://catholicvoiceomaha.com/>
 - Email: tcvomaha@archomaha.org or call 402-558-6611
- Des Moines Diocese Newspaper - The Catholic Mirror:
 - <http://www.dmdiocese.org/catholic-mirror>
 - Email Kelly Mescher Collins (KCollins@dmdiocese.org) or call at 515-237-5054, or Email Anne Marie Cox (ACox@dmdiocese.org) or call at 515-237-5046

- Lincoln Diocese Newspaper – Southern Nebraska Register:
 - <http://www.lincolndiocese.org/snr>
 - Email: <http://www.lincolndiocese.org/contact-us> or call 402-488-0090
- Grand Island Diocese – The West Nebraska Register:
 - <http://www.westnebraskaregister.com/>
 - Email: mary.wnr@gmail.com or colleen.wnr@gmail.com or call 308-382-4660

Feel free to also consider promoting your event through secular media sources such as your local newspapers, secular radio stations, and various social media websites. With advance permission, you may also post your event flyers at neighboring parishes, in local grocery and retail stores, restaurants, gas stations and truck stops.

MANAGE YOUR EXHIBIT

It is a good idea to be mindful of where and how you set up the Eucharistic Miracles of the World exhibit. You will need a reasonable amount of space for the exhibit as it includes 41, 2'x5' panels. You will also need a small table for display-related materials.

Many parishes set up the exhibit either in their church hall, narthex or school gym. When setting up the exhibit, remember to place the panels in proper sequential order by date of when the miracles occurred. See page 6 of this Guide for more details as well as a properly-ordered list of the miracles.

Set Up a Small Display Table Near the Exhibit

You will need a small display table (e.g., 4'x4' or a 6'x6' table is a good size) for the free materials and items listed below that are provided by Spirit Catholic Radio as part of the exhibit. We suggest you cover the table with a nice-looking table cloth and place the table near the entrance of the exhibit.

OFFER HELPFUL FREE MATERIALS PROVIDED BY SPIRIT CATHOLIC RADIO

Spirit Catholic Radio provides some helpful materials as part of the exhibit. These materials may include the following resources:

Eucharistic Miracles of the World Rack Cards –

These handy cards explain the origination of the exhibit and its creator, Bl. Carlo Acutis, as well as other helpful information.

Anima Christi Holy Cards – These wallet-size prayer cards encourage people to spend time in Adoration of Our Lord in the Blessed Sacrament and include the beloved Anima Christi prayer that the faithful often pray after receiving Holy Communion.

Materials continue to next page



Spirit Catholic Radio Program Guides – These helpful guides outline the most popular programs heard on-air on the Spirit Catholic Radio network and encourage people to tune-in and listen!

Spirit Catholic Radio Program Grids – This 8 ½ x 11 flyer illustrates a program grid listing all programs heard on-air, Monday–Friday, between the hours of 5:00 a.m. through 11:00 pm.

Spirit Catholic Radio Tune-In Cards – These wallet-size cards help you find your local Spirit Catholic Radio station by geographic location so you can tune-in and listen to the appropriate FM channel in your area.

Spirit Catholic Radio Bookmarks – These popular bookmarks feature a beautiful photo of the Exhibit's creator, Bl. Carlo Acutis. There is a featured prayer on the card for his cause for sainthood. This is a great card for youth since it highlights the first millennial saint!

Prayer Request Box with Prayer Cards – Spirit Catholic Radio provides a prayer request box and prayer cards for visitors to write and provide their prayer requests to us. We know there is a strength and peace that comes when we pray for one another. Our staff at Spirit Catholic Radio remembers these prayer intentions during our weekly staff prayer before the Exposed Blessed Sacrament each Tuesday morning at 9:30 a.m. in our beautiful Chapel of the Word Incarnate.

Common Questions About Perpetual Adoration Handout – Once your event is booked and confirmed, this 8 ½ x 11 handout will be emailed to you for optional use at your exhibition event. You may choose to make photocopies and include it as a handout during your exhibit. It provides answers to why Perpetual Adoration is important and how it is helpful in increasing our faith in Jesus.

Free-Will Offering Box – Spirit Catholic Radio also provides a locked donation box to accept free-will offerings. We ask you to place this donation box on a small display table near the exhibit. Funds collected are used for the upkeep of the exhibit and for print materials. All donations above expenses are provided to the Real Presence Eucharistic Education and Adoration Association, the non-profit organization who generously allows Spirit Catholic Radio to present the exhibit.

Exhibition Viewing Signage

Once your event is booked and confirmed, Spirit Catholic Radio will provide you with a Word document of 8 ½ x 11 editable signs that you can customize, print and post in your exhibit area to help visitors know where to start viewing the exhibit and which direction to proceed as they view each of the Eucharistic Miracles. See Attachment C for an example of what these signs look like.



PICK-UP, TRANSPORT AND RETURN OF THE EXHIBIT

The parish or organization hosting the exhibit is responsible for both picking it up from and returning it to the Spirit Catholic Radio station.

The exhibit will fit in the back seat or trunk of most regular-sized vehicles. The vinyl panels are rolled together, in numerical order, in four separately-rolled sets of panels. Panels #1-#10 are rolled together as a bundled set, and panels #21-#39 are rolled together as bundled sets of 10 (see the upper left corner of the back of each panel) and each bundle is secured by rubber bands. These four rolls of panels, along with an x-frame stand for each panel, are packed in two red and black, rolling golf travel bags for easy transport. Each golf bag is identical and measures approximately 4'6" long x 1 ½' wide x 11" deep. The 157 panel exhibit travels in 3 wooden box containers.

The table materials will come in an accompanying suitcase or rolling crate.



Spirit Catholic Radio
13326 A Street
Omaha, NE 68144
855-571-0200

Sign the "Acceptance of Stewardship, Care & Responsibility" Form at Pick-Up

When you arrive at the appropriate Spirit Catholic Radio location to pick-up the reserved exhibit for your parish or organization, you will be required to read, acknowledge and sign the "Acceptance of Stewardship, Care & Responsibility" form before the exhibit can be released and entrusted to your care. It is expected and appreciated that you take proper care of the exhibit, as well as repack it and return it in the same manner AND condition as it was received.

PLEASE DO NOT ALLOW YOUTH UNDER AGE 15 TO HANDLE, SET-UP OR TAKE DOWN THE EXHIBIT.

See **Attachment D** for a copy of the "Acceptance of Stewardship, Care & Responsibility" form.

Complete the "Proper Care, Packing & Return Checklist" Form Before Returning Exhibit

When you return the exhibit to the same Spirit Catholic Radio location where you picked it up at, you will be required to provide us with your completed and signed "Proper Care, Packing & Return Checklist" form to ensure the exhibit is properly repacked in an acceptable manner and returned in good condition. We will ask you, before you leave the Spirit Catholic Radio station, to take time to review this form with us, together, so we can inspect the exhibit and the manner in which it was repacked and returned. Please kindly let us know immediately if any stands, exhibit panels, pieces or parts are broken, damaged or missing.

See **Attachment E** for a copy of the "Proper Care, Packing & Return Checklist" form.

SET-UP AND TAKE DOWN OF THE 41 PANEL EXHIBIT

Below is a simple visual guide to setting up the Eucharistic Miracles of the World exhibit.



- Inside the red rolling golf bags, you will find 4 rolls of vinyl Eucharistic Miracles panels and accompanying black plastic x-frame stands. The panels are numbered on the back (top number) to be displayed in numerical sequential order.
- Setting up the x-frame stands is fairly simple. The only caution is to be gentle with the stands, as they are susceptible to breaking/cracking. Sometimes the balls of the feet will fall off or the thin metal piece will detach from the legs. Just simply plug the balls of the feet back on and re-insert the metal piece into the legs to hold the legs together.
- When taking the exhibit down, PLEASE pack away the vinyl panels, easel stands, display materials and the plastic display containers back into the red golf bags EXACTLY the way you received them.
- **In the event any damage occurs, we ask that you please let us know so we can make appropriate repairs and/or replacements.**

SET-UP AND TAKE DOWN OF THE 157 PANEL EXHIBIT

The 157 table exhibit is to be set up on 17 6' tables. You will need an additional table for the Spirit Catholic Radio table materials. This is a total of 18 tables. Two beautiful vinyl panels (plus their stands) will accompany this display. Set them near the exhibit in a highly visible area. You may set these next to the entrance into the room where the display will be held, next to the beginning of the display, or next to the materials table. The panels give a little bit of information on the display, so they are a good way to get people's attention and draw them into the exhibit.

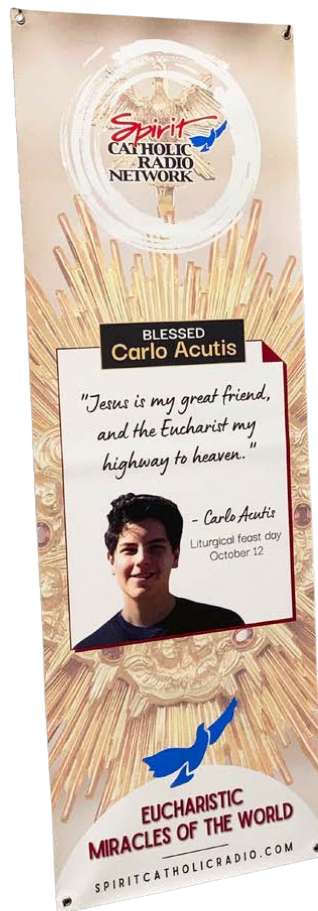

1. Handle with care!
 - Wear gloves.
 - Foam Core Panels are easily damaged – do not drop on corners or edges!
 - Ink is water based. Water drops can smear the ink.
 - Glue is sensitive to temperature variations –keep at room temperature.
 - Do not separate panels that are hinged together.
 - Do not apply tape to any part of the display or storage boxes.
2. Slide lid off box. Overturn box carefully to drop posters on table.
3. This exhibit is designed to be displayed on 3 long rows of tables (36' long each).
4. The strings of posters are arranged alphabetically by country and chronologically within each country. The recommended route allows viewing in this order.
5. Table cloths, appropriate music, flowers and/ or candles are recommended.
6. A glue stick is provided for minor repair of poster corner separating from panel. Contact the printer for major repairs or replacements.
7. Please return the posters in the order removed from the storage boxes.



NO FOOD OR DRINKS

↑ Lift box
up away
from posters.

INK CAN SMEAR!
Avoid rubbing panels
together when removing
or inserting into boxes.

Slide open lid.
Overturn box to drop
posters on table.

Corners are FRAGILE!
Do not crush corners.

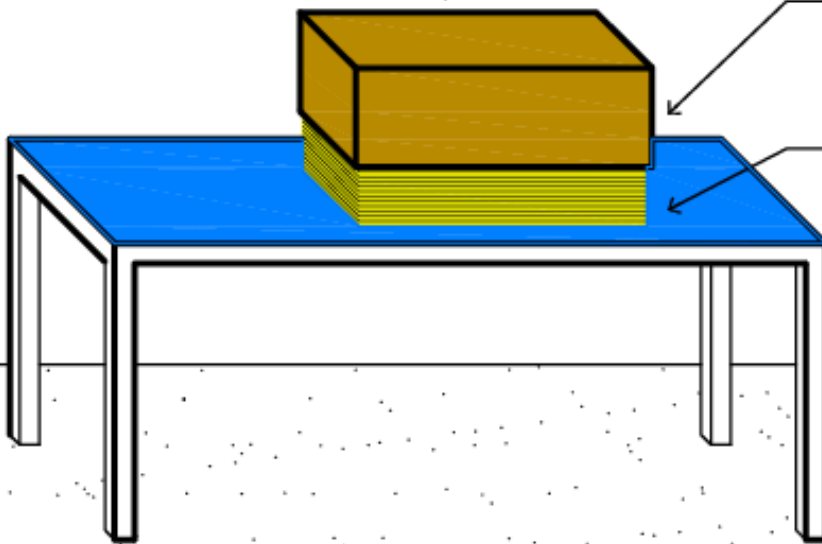

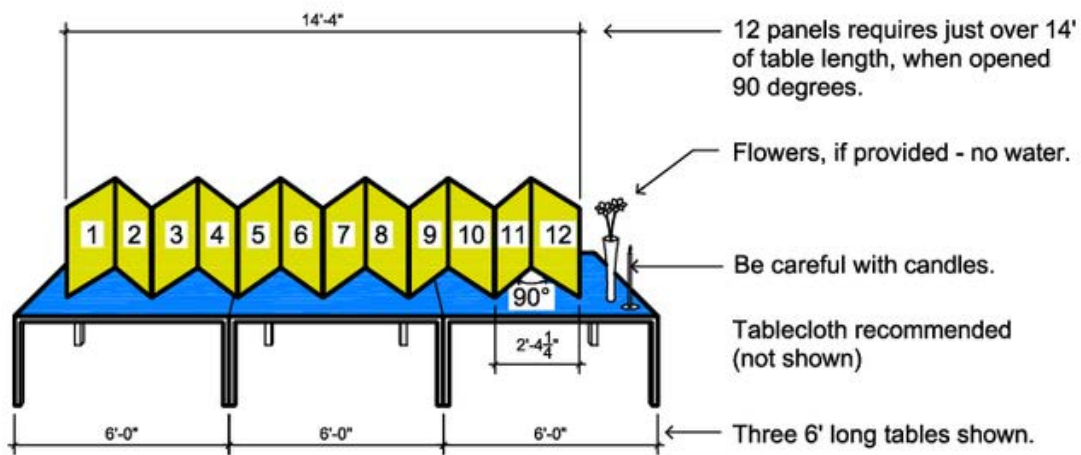

Posters arranged alphabetically by country and then chronologically within each county.

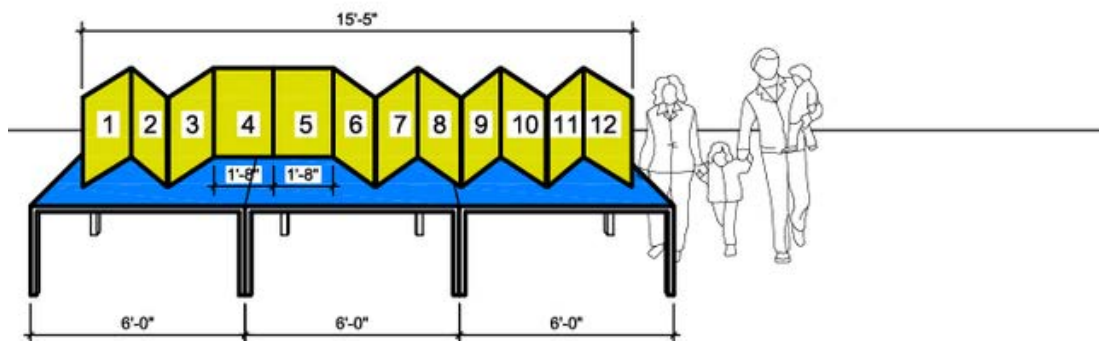

Two or Three related panels may be featured

FLOOR PLAN ALPHABETICAL & CHRONOLOGICAL

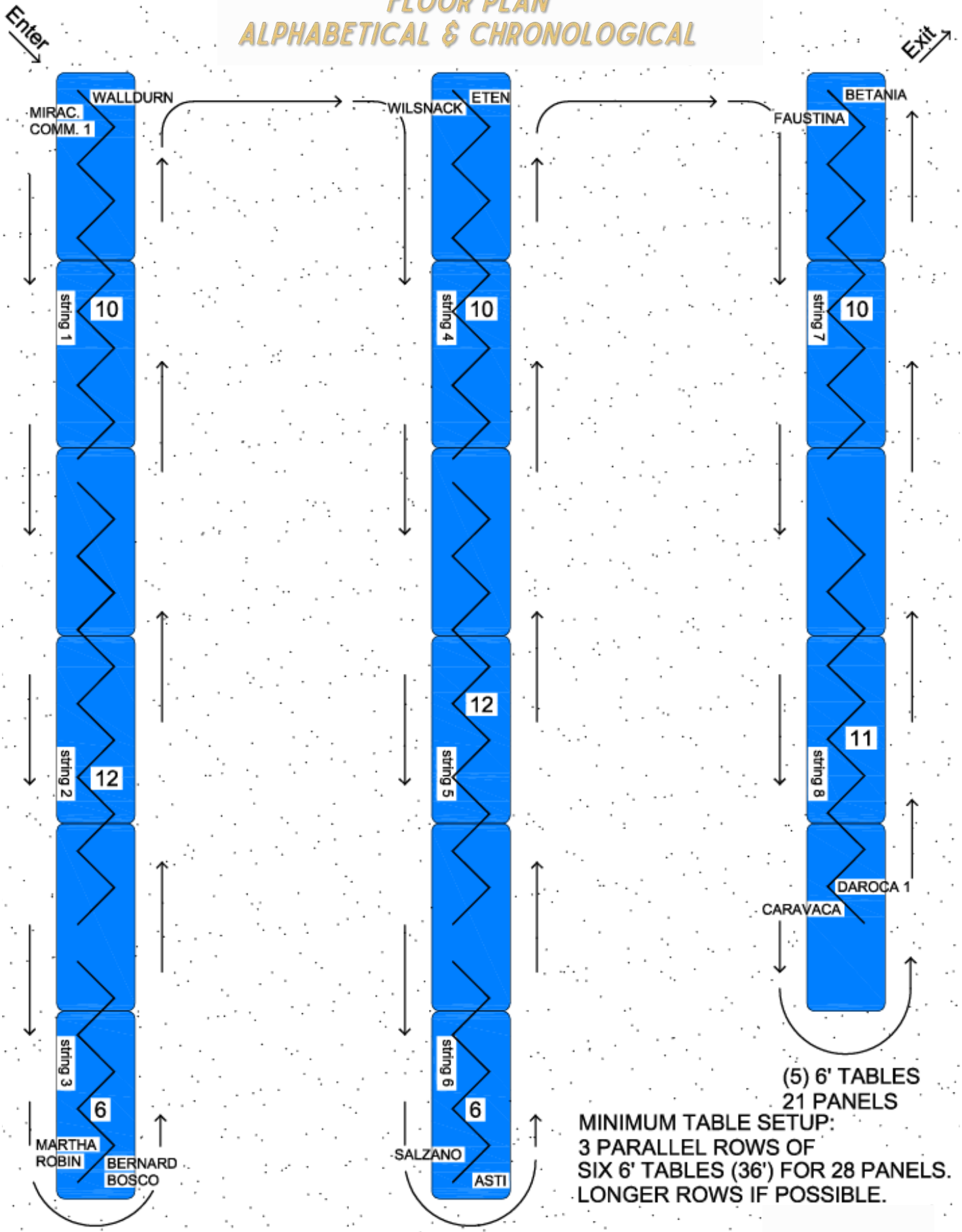

(5) 6' TABLES
21 PANELS

MINIMUM TABLE SETUP:
3 PARALLEL ROWS OF
SIX 6' TABLES (36') FOR 28 PANELS.
LONGER ROWS IF POSSIBLE.

ADDITIONAL INFORMATION ABOUT THE EUCHARISTIC MIRACLES

Provided below are some helpful resources where you can access additional information about the Eucharistic Miracles of the World.

Book of The Eucharistic Miracles of the World

This book is available on Amazon.com and local Catholic book stores:

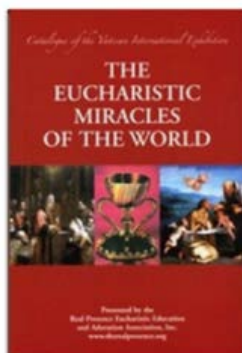

Paperback: 330 pages
Publisher: Eternal Life; 1st edition (2009)
Language: English
ISBN-10: 1931101027
ISBN-13: 978-1931101028
Package Dimensions: 8.9 x 6 x 1 inches
Shipping Weight: 1.4 pounds
Average Customer Review: ★★★★★

Italy Website - <http://www.miracolieucaaristici.org/>

On this website, they have a page where you can search and download each miracle individually, or you can choose to download a full PDF of ALL the miracles and print them, along with some editable leaflets and brochures here:

<http://www.miracolieucaaristici.org/en/Liste/download.html>

You will also find a wonderful Children's Eucharist Video, "The Eucharist, My Highway to Heaven" with three young boys talking about the Eucharist. There is easy access to view it directly from their webpage or you can also download it: <http://www.miracolieucaaristici.org/en/Video/video.html>

This 49-minute video may be shown to children at your Eucharistic Miracles exhibition or at any other appropriate Church event. The video was put together by Antonia Salzano Acutis, and as such, the copyright © 2016 rightfully belongs to her. (Please note that the file for downloading has a full resolution of 1920 x 1080p, and is 845 Mbytes).

Carlo Acutis Website - <http://www.carloacutis.com/en/association/mostra-miracolieucaaristici>

Here you will find out more about Bl. Carlo Acutis, his background, and the cause for his beatification. If you email them at info@carloacutis.com or complete their online form, they will send you some interesting materials and brochures, free of charge and in English, directly from Italy.

BEST PRACTICES: GET YOUTH ENGAGED IN YOUR EXHIBITION EVENT

Our Lady of the Holy Rosary Church in Glenwood, Iowa, displayed the Eucharistic Miracles of the World exhibit to celebrate 20 years of adoration. During this celebration, they were also intent on engaging their youth in learning about the Real Presence of Jesus in the Holy Eucharist. Guided by the Holy Spirit, the co-teachers of the Senior CCD Class, Monica Hughes, Mary Sneed, and Deb DeYoung were inspired with an incredible plan.

First, about two weeks before the scheduled exhibition event, the teachers discussed with the class what a Eucharistic Miracle is. Then they assigned each senior student a Eucharistic Miracle to research. During the CCD class, each student was asked to pull out their cell phone, search for their assigned miracle on the Real Presence Website (see page 17), and study the interesting facts and findings about “their” miracle.

Next, on a Wednesday evening from 6:30 p.m. to 8:00 p.m., the CCD classes viewed the Eucharistic Miracles exhibit together in groups, with phased-in start times arranged by grade level. The Senior CCD Class led the instruction of over 150, 3rd through 11th graders about the Eucharistic Miracles. Each senior stood by their assigned miracle’s panel, and as the youth rotated through the exhibit to view and learn about each miracle, it was the responsibility of each senior to teach and discuss the miracles with the youth.



“The seniors, as well as the younger students, all learned about the Real Presence of Jesus in the Blessed Sacrament. The lives of the youth were forever changed by the amazing holy instruction offered by the seniors regarding the significance of the Holy Eucharist. All the kids were astonished to learn about Eucharistic Miracles dating from 750 AD to 2008 from all over the world. Many commented they would someday like to visit, in person, the places where these miracles actually occurred.”

Mrs. Monica Hughes, Senior CCD Co-Teacher, Our Lady of the Holy Rosary Church, Glenwood, Iowa

FREQUENTLY ASKED QUESTIONS

How big is the exhibit?

One exhibit includes 41 vinyl panels each measuring 2'x5'. Each panel has its own x-frame stand. The other exhibit is 157 panels and sits on 17 tables. See photos in this Guide on pages 5 and 7 for more details.

How many days can I reserve the exhibit?

Your parish or organization may reserve the exhibit from 1-14 days and may pick it up from Spirit Catholic Radio the day before or day of your event. We request you return the exhibit either the day your event ends or the day after your event ends.

Which Eucharistic Miracles are included in the exhibit?

See pages 6-11 in this Guide for a complete list of the Eucharistic Miracles of the World that are a part of Spirit Catholic Radio's traveling exhibits.

Can we receive info sheets or PDFs about each of the Eucharistic Miracles to use for youth or adult education as part of our exhibit event?

See pages 15, 16, 23, 24 of this Guide for additional information about the Eucharistic Miracles of the World where you will find helpful resources and websites that provide downloads of each of the miracles, along with informative articles and a video for children called "The Eucharist, My Highway to Heaven."

Can we invite the Knights of the Holy Eucharist (KHE) to come to our parish or organization to provide a custom talk as part of our event/promotion of the Eucharistic Miracles of the World?

Yes, doing so is highly encouraged. See page 12 of this Guide for information and details on how to contact the Knights of the Holy Eucharist located in Waverly, NE.

Can our exhibition event be promoted on Spirit Catholic Radio's online Events Calendar?

Absolutely! It is your option to complete the online entry form on Spirit Catholic Radio's website to advertise, for free, the Eucharistic Miracles of the World exhibition event at your parish or organization. See page 14 of this Guide to learn how to easily post your event on our calendar.

Will you send me a promotional flyer?

Yes, we will email you a Word template of an editable 8 ½ x 11 flyer (to be customized with your specific exhibition event location, display dates and viewing times).

Will you send me a bulletin announcement and a pulpit announcement?

Yes, see page 13 of this Guide for an editable, customizable paragraph for direct inclusion into your bulletin or for use as a pulpit announcement.

How big of a car do I need to transport the exhibit?

The 41 panel exhibit comes in two red, rolling golf bags and will fit in the back seat or trunk of most regular-sized vehicles. Each golf bag is identical and measures approximately 4'6" long x 1 ½' wide x 11" deep. An SUV with seats down, truck or van is recommended. The 157 panel display travels in 3 boxes. Same vehicles recommended.

Where do I pick up and return the exhibit (where is Spirit Catholic Radio station located)?

You will need to pickup and drop-off the display at our Omaha Station. The address is 13326 A St., Omaha, NE 68144. Please call us at 855-571-0200 if you have questions.

ATTACHMENTS

Attachment A – Sample 8 ½ x 11 Promotional Flyer

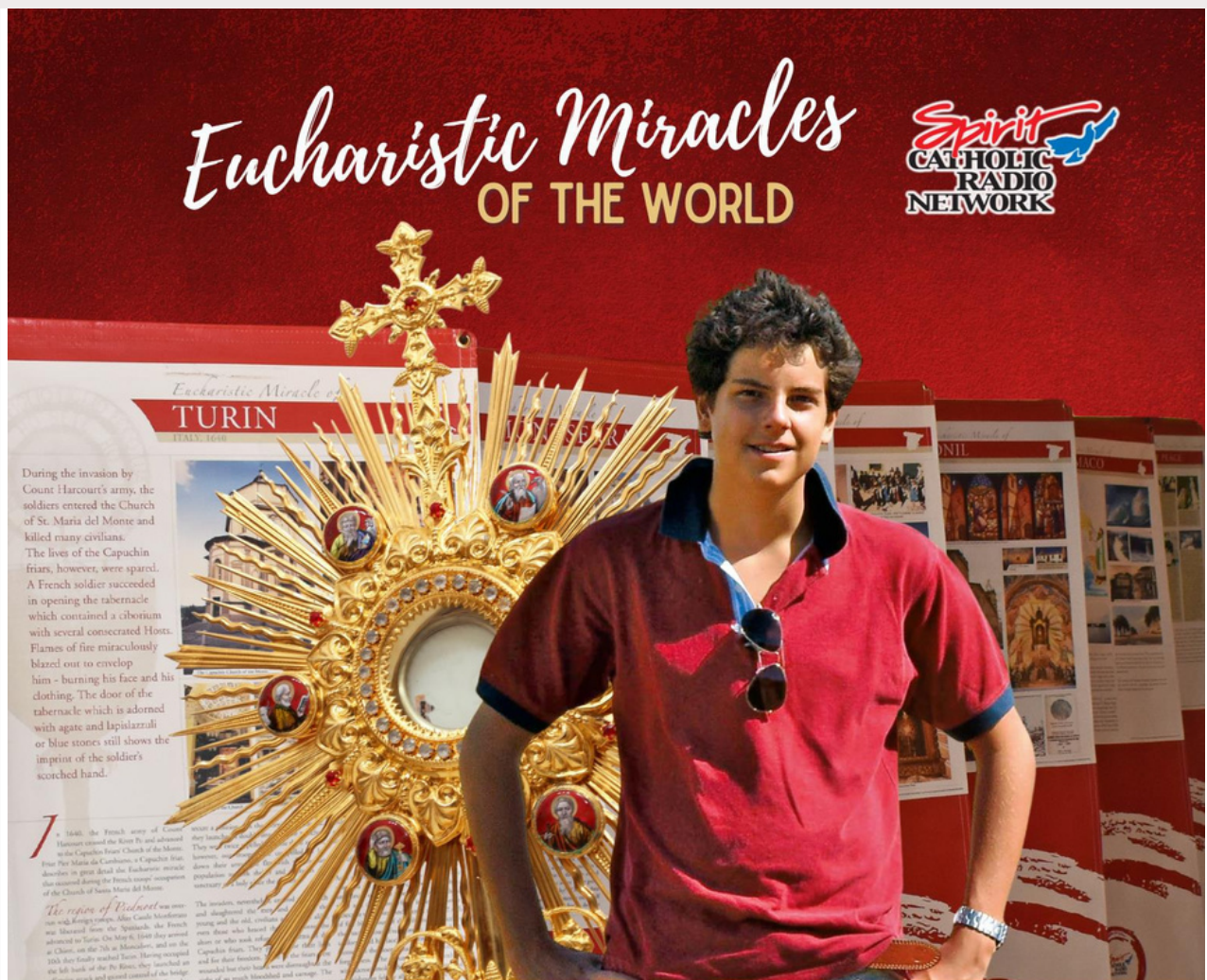

COMING TO CHURCH NAME

VATICAN INTERNATIONAL EXHIBITION DESIGNED BY BLESSED CARLO ACUTIS

The free exhibit features 41 beautiful panels with graphic and written depictions, highlighting some of the most powerful Eucharistic miracles of the world.

THE DISPLAY VIEWING TIMES AND LOCATION

Fill in viewing times here

Display on loan from Spirit Catholic Radio
spiritcatholicradio.com/miracles

Attachment B – Sample Online Calendar Entry

Eucharistic Miracles of the World Coming to Our Lady of the Holy Rosary in Glenwood, Iowa

April 14 @ 9:00 am - April 18 @ 8:30 pm Free



Our Lady of the Holy Rosary Parish in Glenwood, Iowa, will be hosting Spirit Catholic Radio's Eucharistic Miracles of the World exhibit from April 14-18 at Kaufman Hall/Holy Rosary Parish, 24116 Marian Avenue, Glenwood. The display is free to view as follows:

Sat., April 14 – 4 pm to 7:30 pm – Open to public

Sun., April 15 – 9 am to 1 pm – Open to public

Sun., April 15 – 5 pm to 8 pm – For Parish Newcomers & Parish Potluck

Tues., April 17 – 6 pm to 8 pm – Open to public

Wed., April 18 – 6 pm to 8:30 pm – For Holy Rosary Faith Formation youth

The exhibit features 39 beautiful panels that highlight some of the most powerful Eucharistic miracles in the world. For more information, visit spiritcatholicradio.com/miracles.

+ GOOGLE CALENDAR

+ ICAL EXPORT

Details

Start:
[April 14 @ 9:00 am](#)

End:
[April 18 @ 8:30 pm](#)

Cost:
Free

Venue

Our Lady of the Holy Rosary
– Kaufman Hall

24116 Marian Avenue
Glenwood, IA 51534 United
States

Phone:
7125275211

Website:
www.holyrosaryglenwood.com

Organizer

Our Lady of the Holy Rosary

Phone:
7125275211

Email:
holyrosarych@msn.com

Website:
www.holyrosaryglenwood.com

Attachment C - Exhibition Viewing Signage





Perpetual Adoration

What is Perpetual Eucharistic Adoration?

Perpetual Eucharistic Adoration is when a parish sets aside a little room, or chapel, that is open seven days a week, 24 hours a day with permanent exposition of Jesus in the Most Blessed Sacrament.

Why is Perpetual Eucharistic Adoration necessary?

The more we limit the hours of Adoration, the more we limit the availability of Christ to His people. The more we expand the hours, the more we extend the opportunity to adorers. When a chapel is open all the time, then everyone in the parish can participate. Through Perpetual Adoration with exposition we proclaim to our parish and community that Jesus is here, truly present among us today. Pope John Paul II said, "Your faith will help you to realize that it is Jesus Himself who is present in the Blessed Sacrament, waiting for you and calling you to spend one special specific hour with Him each week."

Why is Exposition Necessary?

The difference between spending time with Jesus in the Blessed Sacrament exposed in a monstrance, rather than in the tabernacle, is the same as the difference between conversing with a friend face to face instead of having a closed door between you. Most adorers say that seeing Jesus under the appearance of the Sacred Host is much more conducive to intimacy than Him being hidden in a tabernacle. It helps adorers to be faithful to their scheduled hours, because they know that Jesus cannot be left alone in the Blessed Sacrament exposed in a monstrance. The scheduled adorers are guardians of the Blessed Sacrament, so their presence is necessary. Yet, the most compelling reason for exposition is because the Holy Spirit asks for it. During his Eucharistic discourse, Jesus made this unmistakably clear:

"Indeed, this is the will of My Heavenly Father, that everyone who looks upon the Son and believes in Him, shall have eternal life. Him I will raise up on the last day." John 6:40

What are the benefits?

Each person that spends time in the presence of Jesus in the Most Blessed Sacrament grows in holiness. Communally, increased Mass attendance, conversions, the return of the fallen away Catholics and vocations to the priesthood and religious life are among the many fruits of Perpetual Eucharistic Adoration. Through our Holy Hours of prayer, Our Holy Father declared that we are contributing to "the radical transformation of the world," the "establishing of everlasting peace," and the coming of Christ's Kingdom on earth.